



Technical Datasheet

Contract Flooring Profiles

P.V.C. Trim • Stair Nosings • Expansion Joints • Transitions • Seals • Edge Protection • Metal Trim • Skirting • Tools



Genesis
For the Perfect Finish

Contract Flooring Profiles

Materials for Stair Nosings

Aluminium

Chemical composition: In accordance with BS EN 573-3:2003 Aluminium and aluminium alloys. The trace elements of the composition which determine the alloy selected are 6063 Thermal Treatment designations: T6. To the best of our knowledge this is at least equal to the best in the market.

Manufacturing Tolerance: In accordance with BS EN 755.

PVC Insert

A filled flexible PVC extrusion grade specifically designed for non-scaff stair nosing applications with good anti-slip properties; Physical Properties: Mechanical performance in accordance with BS2782: Method 320A.

Physical Properties: Softness, cold flex & cold bend: In accordance with BS2782.

Physical Properties: Water Absorption: In accordance with BS2782: Method 430A.

Standard PVC Grade

A filled flexible PVC extrusion matt grade (i.e. skirting).

Physical Properties: Mechanical performance: In accordance with BS2782: Method 320A.

Physical Properties: Softness, cold flex & cold bend: In accordance with BS2782.

Physical Properties: Water Absorption: In accordance with BS2782: Method 430A.

Genesis P.V.C. profiles are lead-free and REACH compliant

REACH is a European Union regulation concerning the Registration, Evaluation, Authorisation and restriction of Chemicals. It came into force on 1st June 2007 and replaced a number of European Directives and Regulations with a single system.

REACH has several aims:

To provide a high level of protection of human health and the environment from the use of chemicals.

To make the people who place chemicals on the market (manufacturers and importers responsible for understanding and managing the risks associated with their use.)

To allow the free movement of substances on the EU market.

To enhance innovation in and the competitiveness of the EU chemicals industry.

To promote the use of alternative methods for the assessment of the hazardous properties of substances e.g. quantitative structure-activity relationships (QSAR) and read across.

REACH applies to substances manufactured or imported into the EU in quantities of 1 tonne or more per year. Generally, it applies to all individual chemical substances on their own, in preparations or in articles (if the substance is intended to be released during normal and reasonably foreseeable conditions of use from an article).

Almost every business in the UK will have a new responsibility under REACH. There are three main types of REACH dutyholder

- Manufacturers/Importers
- Downstream users
- Other actors in the supply chain (i.e. distributors, suppliers)

Cleaning & Maintenance Instructions

As Genesis stair nosing's have a slip resistance function regular cleaning and maintenance to avoid the build of dirt or other contaminants such as floor polish is essential. Regular cleaning is also necessary to ensure the long-term appearance retention of Genesis products.

Inserts

PVC inserts should be cleaned using a neutral detergent until all deposits of dirt or contaminants have been removed. This should be followed by a thorough rinsing with clean water following which the nosing should be dried. Under no circumstances should the stair nosing be walked on until fully dry.

Alloy Channel

Stair nosing channel may be cleaned using a neutral detergent. It may also be lightly polished using fine steel wool to enhance the long-term appearance.

Note

Under no circumstances should cleaning agents containing solvents be used on any Genesis products.

Technical Datasheet

Contract Flooring Profiles

Drilling Instructions - Slimline

Drill using Genesis countersunk drill bit

Start 75mm from each end and set all holes equally as indicated for single and double channel.

Length	No. of Holes
600 - 699	2
700 - 1099	3
1100 - 1399	4
1400 - 1799	5
1800 - 2099	6
2100 - 2499	7
2500 - 2799	8
2800 - 3200	9

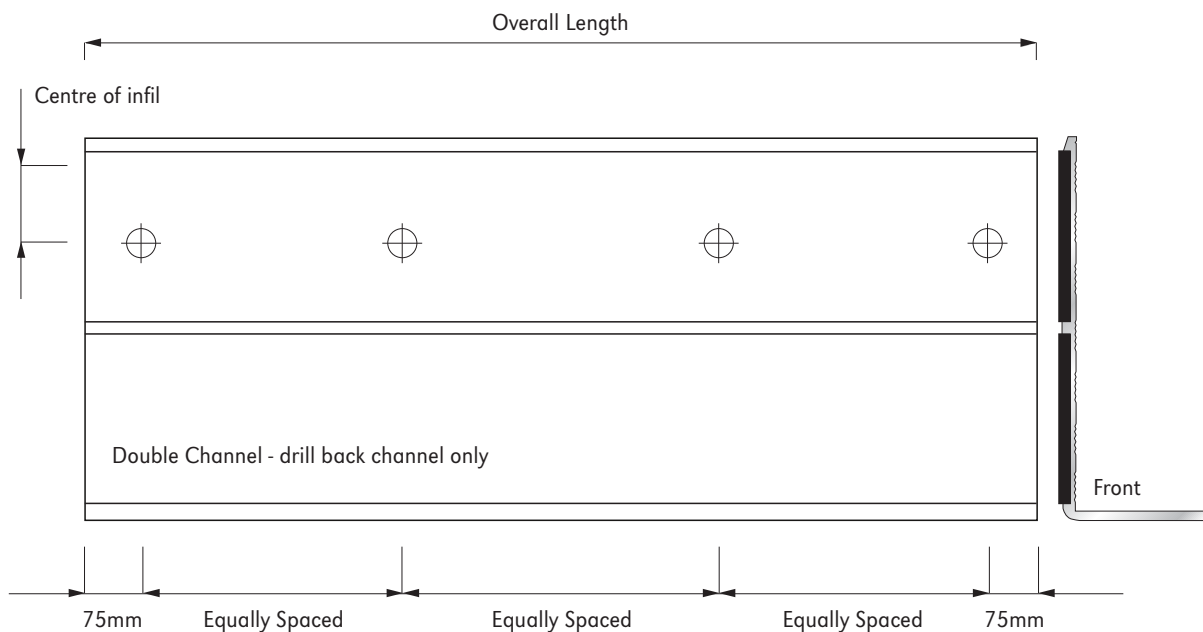
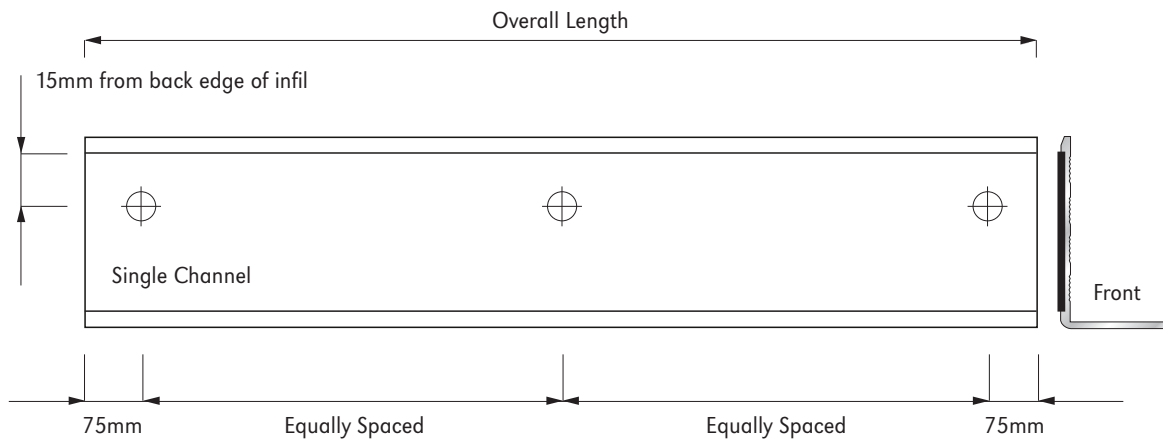
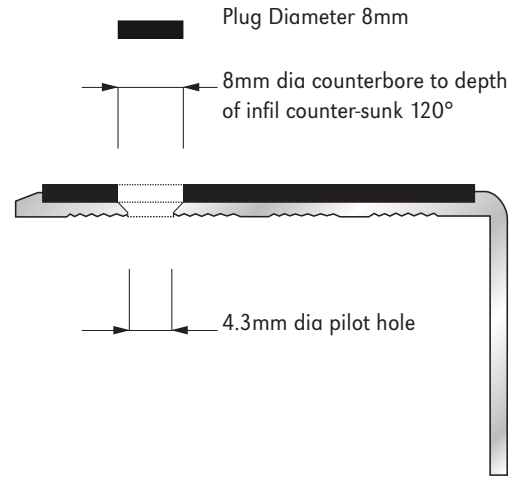

Technical Datasheet

Contract Flooring Profiles

Drilling Instructions - Heavy Duty

Drill using Genesis countersunk drill bit

Start 75mm from each end and set all holes equally as indicated for single and double channel.

Length	No. of Holes
600 - 699	2
700 - 1099	3
1100 - 1399	4
1400 - 1799	5
1800 - 2099	6
2100 - 2499	7
2500 - 2799	8
2800 - 3200	9

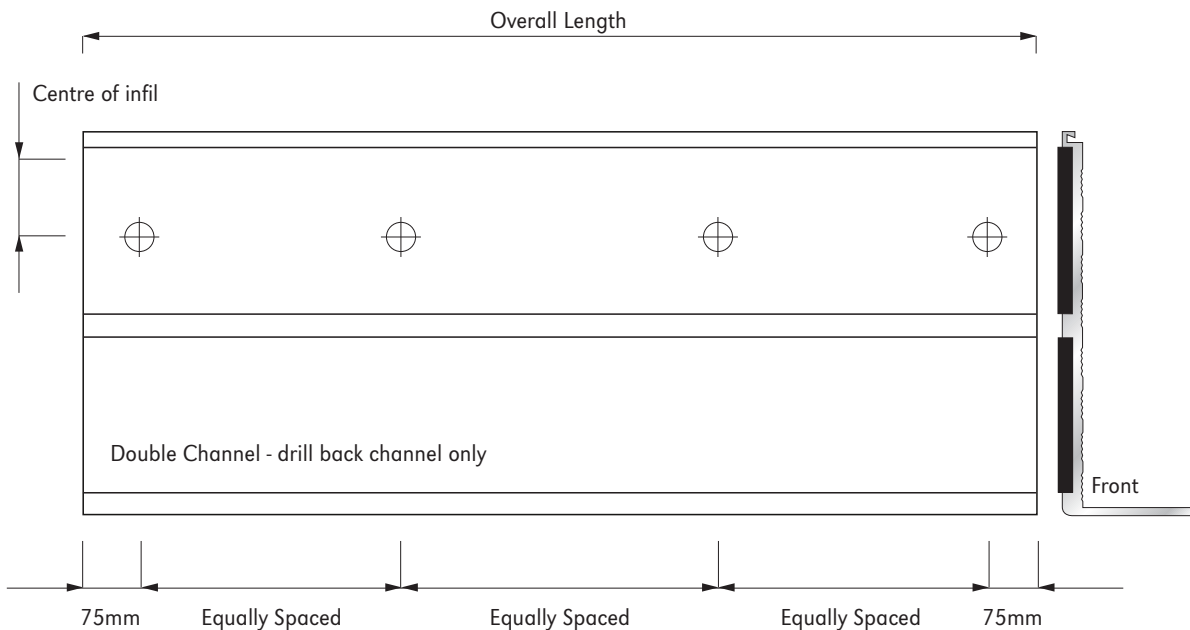
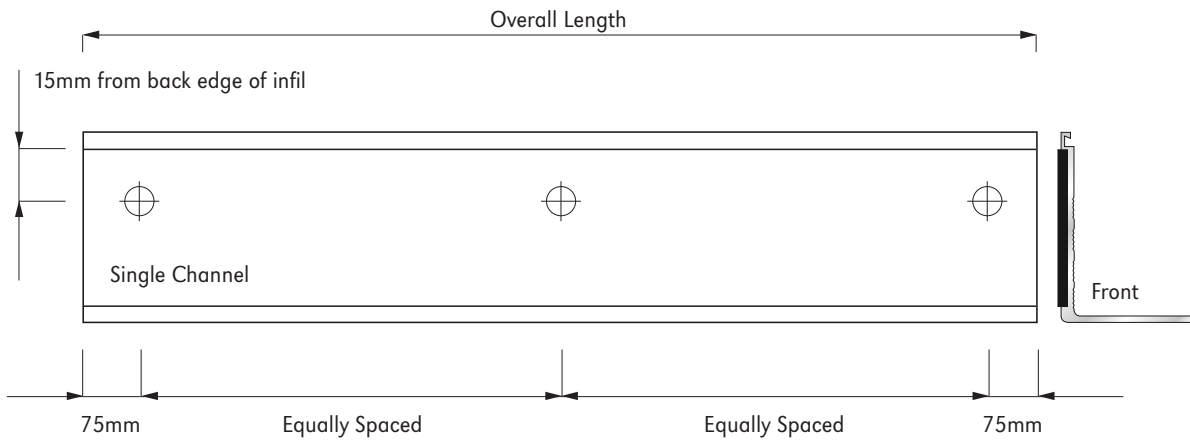
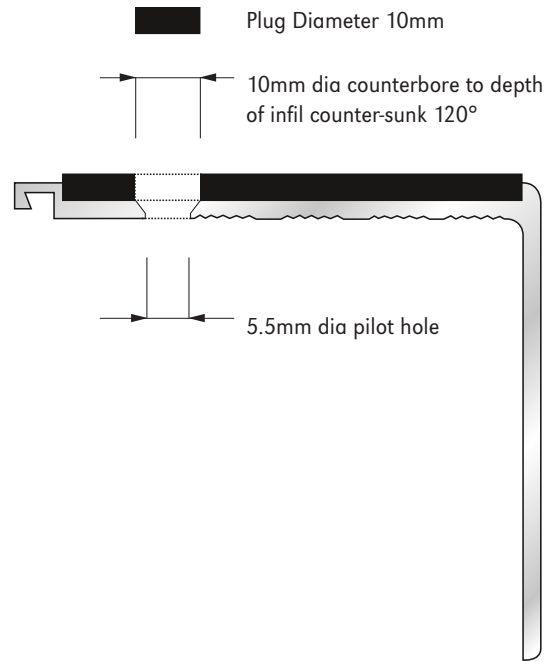

Technical Datasheet

Contract Flooring Profiles

Installation - Mechanical Fix



1
Prepare surface, it must be clean, smooth and free of debris.



2
Position the profile, check the fit and mark the drill holes.



3
Drill and Plug to suit the screw size.



4
Apply adhesive as per manufacturer's instructions.



5
Position onto step.



6
Mechanically fix.



7
Insert plug.



8
Remove protective film when applicable.

If fixing inserts separate follow steps 1 – 6, remove release paper from channel and position insert ends flush applying pressure towards the centre finishing with hand roller to ensure adhesion.

Installation - Flexy Fix



1
Prepare surface, it must be clean, smooth and free of debris.



2
Apply 5mm bead to the underside of the profile, 2 lines for Single and 3 for double channel.



3
Position, press and slide to ensure full bond.

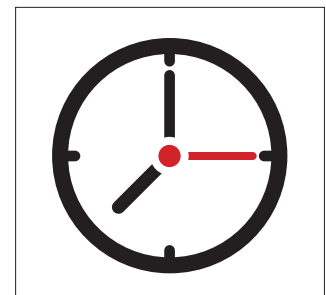

4
Allow 1 hour (minimum) after fixing. It is the contractor's responsibility to ensure the bond is secure before opening the area.

Genesis recommend Flexy Fix adhesive, for full technical advice visit www.rewmar.co.uk or call 0333 800 1966

Technical Datasheet

Contract Flooring Profiles

Specification Guidelines – Light Reflectance Values (LRV's)

British Standards BS8300 : 2009 states that light reflectance values (LRV's) are used to assess visual contrast using the method of measurement detailed in BS8493 : 2008. Approved Document M (ADM 2004) directly refers to colour and contrast in the definitions, stating:

“Contrast visually, when used to indicate the visual perception of one element of the building, or fitting within the building, against another means that the difference in light reflectance value between the two surfaces is greater than 30 points”.

LRV's – Clarification

Reflectance is the proportion of light that a surface reflects compared to the amount or volume of light that falls on the said surface. An LRV is a value given to a surface to identify the amount of light reflected. People with impaired vision can perceive light and dark, therefore LRV's are a suitable method to measure contrast between 2 different surfaces.

Note that dark, matt or textured surfaces absorb a large amount of light, therefore have low reflectance values, however a combination of one or all light, shiny or smooth surfaces reflect the majority of light and therefore have higher reflectance values.

In order to achieve a suitable contrast between different surfaces, ADM 2004 recommend at least a 30 point difference in the LRV's of the two contrasting surfaces.

Genesis Stair Nosings Colour and Contrast BS8300 : 2009

Each step and nosing should incorporate a permanently contrasting continuous material for the full width of the stair on both the tread and the riser to help blind and partially sighted people appreciate the extent of the stair and identify individual treads. The material should be 50 mm to 65 mm on the tread and 30 mm to 55 mm on the riser, and should contrast visually with the remainder of the tread and riser.

Colour / Contrast Perception

The nosing of every flight of stairs should be adequately colour or luminance contrasted with the remainder of the step and the floor coverings adjacent to the top and the bottom of the flight.

Genesis Stair Nosing Inserts and Light Reflectance Values

Genesis Colour	LRV	RAL
01 White	79.9	9003
16 Black	4.5	9004
20 Brown	9.1	8014
25 Beige	41.1	1001
27 Canvas	53.2	1013
28 Green	6.3	6005
30 Red	10.6	3031

Genesis Colour	LRV	RAL
43 Dolphin Grey	27.6	7042
44 Ice Grey	42.1	7001
46 Midnight Grey	12.8	7024
47 Yellow	55.7	1018
48 Cobalt Blue	9.2	5000
109 Sky Blue	13.5	5015
113 Tangerine	N/A	2000

Please note the RAL numbers in the above table is a guide only. Genesis do not manufacture to RAL numbers and cannot guarantee an exact match as there are a number of variables within the manufacturing process.

Contract Flooring Profiles



Slip-resistance tests have been independently undertaken by Lucideon Ltd using the pendulum and inclined platform test.

Nosing Insert Slip Resistance

Inclined Platform Test DIN 51130:2010

	Operator 1 - Angle of Inclination	Operator 2 - Angle of Inclination
1	23.6°	22.3°
2	23.5°	21.0°
3	24.4°	22.7°

Average of Six Shod Results (Corrected): 22.9°

Category: R11

The critical angle at which a test person reaches the limit of safe walking on an inclined plane is used as a measure of slip resistance.

Pendulum Test BS 7976-2:2002

PTV Average Dry Value: 66

PTV Average Wet Value: 54

The energy absorbed by contact with the pre-set distance is read from a physical scale by a pointer that follows the overswing of the pendulum arm. 12 results are averaged to give the final pendulum number which is used to categorise the tile surface.

The UK slip resistance group recommends the following guidelines;

PTV	Slip Potential
0-24	High
25-35	Moderate
36+	Low

Contract Flooring Profiles

Specification Guidelines

The Building Regulations 2000 – Approved Document M “Access to and use of buildings”

The Building Regulations and British Standards are designed to ensure the optimum specification of products through a combination of legislative requirements and guidance. The following extracts have been taken from The Building Regulations 2000 and British Standards BS830:2001 and show how Genesis Systems products can be used to help satisfy these requirements, and help achieve an inclusive environment in line with the Disability Discrimination Act 1995 (DDA).

Building owners have a legal duty to ensure all people can gain access to and use a building and its facilities. Approved documents are intended to provide guidance and much of the guidance in Approved Document M is based on BS8300:2001. The main points relating to stair and stepped access detailed in Approved Document M are shown as follows, with our own recommendations:

Stepped Access:

- 1.27 People with impaired sight risk tripping or losing balance if there is no warning that steps provide a change in level.
- 1.29 Materials for treads should not represent a slip hazard, especially when the surface is wet.
- 1.30 People should easily be able to appreciate where to place their feet by highlighting nosings and avoiding open risers.
- 1.33 All nosings are made apparent by means of a permanently contrasting material 55mm wide on both the tread and 30-55 on the riser.

Entrance Lobbies:

- 2.29 (e) Floor surface materials within the lobby do not impede the movement of wheelchairs e.g. not coir matting, and changes in floor materials do not create a potential trip hazard.
- 2.29 (f) The floor surface helps to remove rainwater from shoes and wheelchairs.
- 2.29 (g) where matwells are provided, the surface of the mat is level with the surface of the adjacent floor finish.

Corridors and Passageways:

- 3.12 In order to help people with visual impairment to appreciate the size of a space they have entered, or to find their way around, there should be a visual contrast between floor and wall.

BRE - Research and Guidelines

BRE has published an information paper (ref. IP15/03) entitled “Proprietary nosings for non-domestic stairs”. This paper provides guidance to designers and building managers on the best ways to assess the types of proprietary nosings that should be provided on non-domestic stairs.

Detailed below is an overview and summary of the key findings in the BRE information paper.

Overview

The study considered the dynamics of pedestrian stair use. Previous studies have shown that 80% of slips on stairs are likely to occur when users are descending the stairs. This usually occurs as a result of an overstep (i.e. when a substantial portion of the foot overhangs the tread). Therefore as the going (tread width) becomes narrower the likelihood of a slip incident becomes greater. Where the going is less than 300mm the risk of slip is increased. Most non-domestic stairs have a going of between 250mm and 280mm. The risk of slip is further increased if the tread surface is smooth, becomes wet or there is a lack of clear colour contrast at the step edge.

Conclusion

The application of a proprietary nosing may reduce the risk of slipping against the factors highlighted above. The proprietary nosing should incorporate a slip-resistant material that should extend to the point at which it meets the vertical face to minimise the risk of slip in descent. Proprietary nosings should all offer a colour contrast to clearly highlight the step edge.

Contract Flooring Profiles

Specification Guidelines

BS8300:2009 + A1:2010:

Design of buildings and their approaches to meet the needs of disabled people. Code of practice

This standard provides guidance or good practice in the design of domestic and non-domestic buildings and their approaches so that they are convenient to use by disabled.

Guidance on Stair Edgings:

5.9.5 Identification and slip resistance of nosing

Each step nosing should incorporate a permanently contrasting continuous material for the full width of the stair on both the tread and the riser to help blind and partially sighted people appreciate the extent of the stair and identify individual treads. The material should be 50mm to 65mm on the tread and 30mm to 55mm on the riser, and should contrast visually with the remainder of the tread and riser.

NOTE 1 A nosing that wraps around the riser might assist blind or partially sighted people.

NOTE 2 A proprietary nosing can provide a durable solution that satisfies both visual contrast and slip resistance criteria (see BRE IP 15/03 [13]).

The whole tread or the nosing should incorporate slip-resistant material, starting as close as practicable to the front edge of the nosing and extruding the full width of the tread.

NOTE 3 Guidance on slip resistance of surfaces is given in Annex E.

8 Vertical circulation

8.1 Internal steps and stairs

8.1.5 Surface finishes

The surface materials used for internal steps and stairs should be chosen to be easy to maintain and as slip-resistant as possible, especially if surfaces are likely to become wet due to location or use, or if spillage occurs.

NOTE Advice and further reference on slip resistance of surfaces is given in Annex E.

Annex E

Slip potential characteristics of treads, ramp surfaces and floor finishes:

E.2 Slip resistance

The following indices are used to indicate the slipperiness of surfaces:

- a) pendulum test values (PTV's) obtained using a pendulum tester in line with BS 7976-2;
- b) surface micro-roughness (Rz) measurements using a stylus instrument in accordance with BS 1134-1.

E.5 Step nosings

Where slip resistance is required for nosings and treads, the slip resistance needs to be the equivalent to that expected for level surfaces. A PTV greater than 36 is considered to be suitable, as pushing and turning are unlikely on stairs. On existing nosings, the slip resistance of step nosings are generally expressed by their Rz roughness value as PTV is difficult to measure. In such cases a roughness Rz value of 20µm is recommended.

Guidance on Tactiles:

5.9.6 Landings

To give advance warning of a step, tactile paving with a hazard warning surface should be provided at the top and bottom of each flight.

Where the approach to the stair is wider than the flight, the tactile surface should extend beyond the line of each edge of the flight.

NOTE Further information on the correct choice of tactile warning surface can be found in the DTLR publication Guidance on the use of tactile paving surfaces.

Guidance on Skirtings:

9 Surface and communication aids

9.1.1 Visual characteristics

The LRV of a wall should be 30 points different from that of the ceiling and of the floor. To avoid giving the wrong impression about the size of a room, skirtings should have the same LRV as the wall so that the junction between the skirting and the floor marks the extent of the room.

For more information contact Genesis today

Tel: +44 (0)1642 713000 Email: info@genesis-gs.com

www.genesis-gs.com



Stokesley Business Park
Stokesley North Yorkshire TS9 5JZ

