

Mortar Mixer

 Read before use

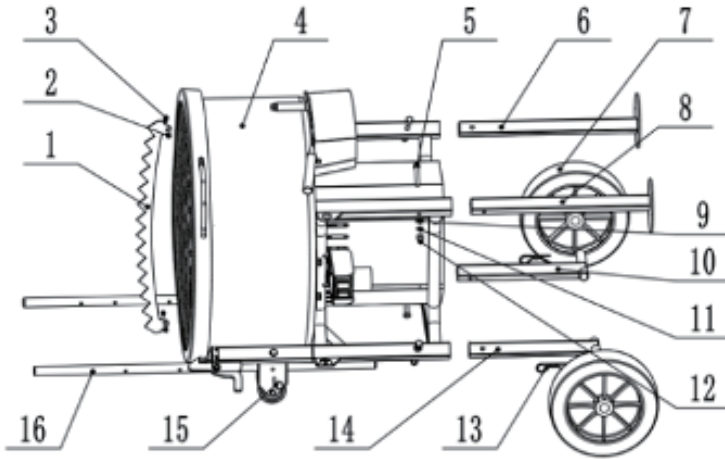

Spare Part List











1	The sawtooth (x1)	9	Washer M10 (x4)
2	Nut M6 (x2)	10	Right wheel bracket (x1)
3	Bolts M6X16 (x2)	11	Spring washer M10 (x4)
4	Drum (x1PC)	12	Cup nut M10 (x4)
5	Bolts M10X55 (x4)	13	Ear pin (x2)
6	6.Right leg (x1)	14	Left wheel bracket (x1)
7	7.Wheels (x2)	15	Spring pin (x2)
8	8.Left leg (x1)	16	Auxiliary handle (x2)

INDEX

- 1 Safety Warnings
- 2 Application
- 3 Assembly Instructions
- 4 Using Instructions
- 5 Cleaning and Maintenance
- 6 Accessories
- 7 Environmental Protection
- 8 Warranty
- 9 Attachments

Symbols

The following are the icons that are used for the tool. Make sure you fully understand them before using them.

	Read the instruction manual		Class II machine
	CE mark		Wear safety gloves
	Caution		Wear hearing protectors
	Conforms to WEEE		Wear safety glasses
	Class II machine		Warning risk of cutting by the saw
			Use of segmented blades prohibited

1. Safety Warnings

⚠ Caution

Read all safety instructions and warnings provided with power tool. Failure to follow the instructions below may result in electric shock, fire and / or serious injury.

Keep all warnings and instructions for future reference.

The term "power tool" used in the safety instructions refers to mains operated power tools (with power cord) or to battery operated tools (without power cord).

General safety warnings for power tools

1.1 Safety in work area

- a) **Keep your work area clean and well lit.** Disarray or unlit work areas can lead to accidents.
- b) **Do not work with the power tool in a potentially explosive environment in which flammable liquids, gases or dusts are present.** Power tools generate sparks that can ignite the dust or fumes.
- c) **Keep children and bystanders away while using the power tool.** Distractions can result in a loss of control.

1.2 Electrical Safety

- a) **The plug of the power tool must fit into the socket. The plug must not be changed in any way.** Do not use adapter plugs together with electrically grounded power tools. Unmodified plugs and matching sockets reduce the risk of electric shock.
- b) **Avoid body contact with grounded surfaces such as pipes, heaters, stoves, and refrigerators.** There is an increased risk of electric shock if your body is grounded.
- c) **Keep power tools away from rain or moisture.** The penetration of water into a power tool increases the risk of electric shock.
- d) **Do not misuse the power cord to carry the power tool, hang it up, or unplug it from the power outlet.** Keep the connection cable away from heat, oil, sharp edges or moving parts. Damaged or entangled leads increase the risk of electric shock.
- e) **When working outdoors with a power tool, only use extension cables that are also suitable for outdoor use.** Using an extension cord suitable for outdoor use reduces the risk of electric shock.
- f) **If operation of the power tool in a damp environment is unavoidable, use a residual current device.** Using a residual current circuit breaker reduces the risk of electric shock.

1.3 Personal Safety

- a) **Be attentive, pay attention to what you are doing and be reasonable about working with a power tool. Do not use a power tool when you are tired or under the influence of drugs, alcohol or medication.** A moment of carelessness when using the power tool can cause serious injury.
- b) **Wear personal protective equipment and always safety goggles.** Wearing personal protective equipment such as a dust mask, non-slip safety shoes, hard hat or ear protection, depending on the type and use of the power tool, reduces the risk of personal injury.
- c) **Avoid unintentional startup. Make sure that the power tool is switched off before connecting, receiving or carrying it to the power supply and / or the battery.** Keeping your finger on the switch when you are wearing the power tool or plugging the power tool into power can cause an accident.
- d) **Remove setting tools or wrenches before turning on the power tool.** A tool or key located in a rotating part of the power tool can cause injury.
- e) **Avoid an abnormal posture. Ensure a secure footing and maintain balance at all times.** This allows you to better control the power tool in unexpected situations.
- f) **Wear suitable clothing. Do not wear loose clothing or jewelry.** Keep hair and clothing away from moving parts. Loose clothing, jewelry or long hair can be caught by moving parts.
- g) **If dust extraction and collection equipment can be installed, they must be connected and used properly.** Using a dust extractor can reduce dust hazards.
- h) **Do not weigh yourself in false safety and do not overstep the safety rules for power tools, even if you are familiar with the power tool after many uses.** Careless action can lead to serious injuries within fractions of a second.

1.4 Use and care of the power tool

- a) **Do not overload the power tool. Use the appropriate power tool for your work.** With the right power tool you work better and safer in the specified power range.
- b) **Do not use a power tool whose switch is defective.** A power tool that can not be turned on or off is dangerous and must be repaired.
- c) **Unplug the power cord and / or remove a detachable battery before making any adjustments to the device, changing the tool bits, or putting the power tool away.** This precaution prevents the unintentional start of the power tool.
- d) **Store unused power tools out of the reach of children. Do not allow persons to use the power tool that are unfamiliar or have not read these instructions.** Power tools are dangerous when used by inexperienced people.
- e) **Maintain power tools and insert tools with care. Check that moving parts are working properly and do not jam, that parts are broken or damaged enough to impair the functioning of the power tool. Have damaged parts repaired before using the power tool.** Many accidents are caused by badly maintained power tools.
- f) **Keep cutting tools sharp and clean.** Carefully maintained cutting tools with sharp cutting edges become less jammed and easier to guide.
- g) **Use power tools, accessories, tools etc. according to these instructions. Take into account the working conditions and the activity to be performed.** The use of power tools for other than intended applications can lead to dangerous situations.
- h) **Keep handles and grips dry, clean and free of oil and grease.** Slippery handles and gripping surfaces do not allow safe operation and control of the power tool in unforeseen situations.

1.5 Use and care of the battery tool

- a) **Charge the batteries only with chargers recommended by the manufacturer.** A charger suitable for a particular type of battery may cause a fire when used with other batteries.
- b) **Use only the appropriate batteries in the power tools.** Use of other batteries may cause injury or fire.
- c) **Keep the unused battery away from paper clips, coins, keys, nails, screws, or other small metal objects that could cause the contacts to bridge.** A short circuit between the battery contacts can cause burns or fire.
- d) **If used incorrectly, liquid may leak from the battery. Avoid contact with it. In case of accidental contact, rinse with water. If the fluid gets into your eyes, seek additional medical attention.** Leaking battery fluid may cause skin irritation or burns.
- e) **Do not use a damaged or modified battery.** Damaged or altered batteries can behave unpredictably and cause fire, explosion or injury.
- f) **Do not expose a battery to fire or high temperatures.** Fire or temperatures over 130 ° C can cause an explosion.
- g) **Follow all charging instructions and never charge the battery or the cordless tool outside the temperature range specified in the operating instructions.** Incorrect charging or charging outside the permitted temperature range can destroy the battery and increase the risk of fire.

1.6 Service

- a) **Only have your power tool repaired by qualified personnel and only with original spare parts.** This ensures that the safety of the power tool is maintained.
- b) **Never use damaged batteries.** All battery maintenance should only be done by the manufacturer or authorized service centers. Follow the instructions for lubricating and changing accessories.

Additional safety warnings from the manufacturer

- UNDERSTAND YOUR MIXER.

Read and understand the users manual and labels affixed to the mixer. Learn its application and limitations as well as the specific potential hazards peculiar to it.

- STAY ALERT.

Do not operate the mixer while under the influence of drugs, alcohol, or any medication that could affect your ability to use it properly. Do not use this mixer when you are tired or distracted from the job at hand. Watch what you are doing at all times. Use common sense

- AVOID DANGEROUS CONDITIONS.

Make sure there is adequate surrounding workspace.

Keep your work area clean and well lighted. Cluttered areas invite injuries.

Keep area around the mixer clear of obstructions, grease, oil, trash and other debris which could cause persons fall into moving parts. Only use or operate the mixer on solid, flat, level ground that is capable to support the weight of the mixer and its load to prevent the mixer from tipping over.

Do not attempt to move the mixer when it is loaded and/or in operation.

This mixer is intended for the production of concrete, mortar and plaster. It is not suitable for the mixing of flammable or explosive substances. Do not use it in areas where fumes from paint, solvents or flammable liquids pose a potential hazard.

- INSPECT YOUR MIXER.

Check your mixer before turning it on. Keep guards in place and in working order. Do not plug mixer with motor cover off. Check all bolts, nuts and screws for tightness before each use, especially those securing guards and drive mechanisms. Vibration during mixing may cause these to loosen.

Form a habit of checking to see that all the adjusting tools, shovels, trowels and other tools/equipment are removed from mixer area before turning it on.

Replace damaged, missing or failed parts before using it. Warning labels carry important information. Replace any missing or damaged warning labels.

- DRESS PROPERLY.

Do not wear loose clothing, gloves, neckties or jewelry (rings, wrist watches). They can be caught in moving parts. Protective electrically non-conductive gloves and non-skid footwear are recommended when working. Wear protective hair covering to contain long hair, preventing it from getting caught in machinery. Wear a face or dust mask if the operation is dusty. Always wear safety goggles and /or face shields.

- DO NOT ABUSE CORD.

Never carry mixer by cord or yank it to disconnect it from socket. Keep cord from heat, oil and sharp edges.

- EXTENSION CORDS.

Extension cords must be no longer than 50 meters in length. The wire section must be 1.5mm² on 230V to allow sufficient current flow to the motor. Improper use of extension cords may cause inefficient operation of the mixer which can result in overheating and motor damage.

Only extension cords to H07RN-F specification intended for outdoor purpose may be used. Avoid use of free and inadequately insulated connections. Connections must be made with protected material suitable for outdoor use. Make sure that any extension cord is carefully laid out avoiding liquids, sharp edges and places where vehicles might run over it. Avoid allowing the extension cord to be trapped underneath the mixer. Unroll it fully or it will overheat and could catch fire.

- DO NOT FORCE TOOL.

It will do a better and safer job at its design rate. Always work within the rated capacity. Do not start the motor if the drum is fully loaded. Do not turn mixer off while full of concrete. Do not use the mixer for a purpose for which it was not intended. The mixer is not to be towed by any vehicle.

- NEVER LEAVE MIXER RUNNING UNATTENDED

Do not leave mixer until it has come to a complete stop.

- DISCONNECT POWER.

Never open the motor cover before unplugging the mixer. Disconnect from power supply when not in use, before moving making adjustments, changing parts, cleaning, or working on the mixer. Consult technical manual before servicing.

2. Specification

Power	1500W
Voltage	230V
Frequency	50HZ
Motor Power	1600RPM
Drum Capacity	120L
Drum Mouth Diameter	27.2inches
Drum Rotate Speed	30RPM
Loading	120kgs
Overall Dimensions	760 x 820 x 1170mm
Net Weight	127kgs

3. Instructions

- Two people assist in assembly recommended
- Please prepare all the parts follow to the parts list.
- Contents of the shipping container

3.1 Assemble the wheel stand



3.2 Assemble the bracket and wheel stand

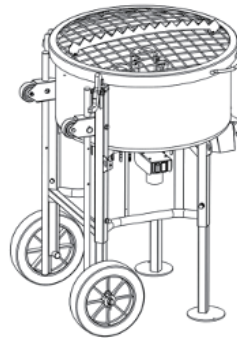

3.3 Assemble the auxiliary handle (No. 16) and sawtooth (No. 1)

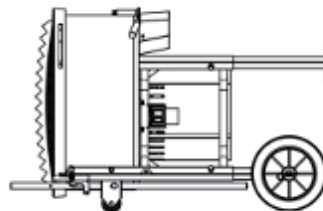

4. Cleaning and Maintenance

- **Maintain your mixer with care.** Clean the mixer immediately after use. Keep the mixer clean for best and safest performance. When maintaining this mixer, only the manufacturer's original replacement parts may be used.
- **Store idle equipment.** When not in use, the mixer should be stored in a dry location to prohibit rust. Keep the mixer away from children and others not qualified to use it.

5. Environmental Protection

- Do not dispose of electrical appliances in the household waste.
- Follow the local provisions for the disposal of electrical or battery products.
- Valuable materials can be recovered by recycling.
- The electrical or battery components used for construction are in accordance with the regulation European Directive 2012/19 / EU on waste electrical and electronic equipment and transposition into national law., used electrical appliances must be collected separately and recycled in an environmentally sound manner.
- Contact us for further information.



6. Warranty

- The guarantee covers all manufacturing or assembly defects in accordance with the legislation in force. The guarantee does not cover malfunctions caused by improper use, overloads, failure to follow the operating instructions and normal wear and tear.
- For more details and information, consult the general guarantee conditions at www.bihuitools.com



www.bihuitools.com